

REVISIONS			
REV.	DESCRIPTION	DATE	APPROVED
A	PRODUCTION RELEASE [ECO 240016]	01/24	
B	CHANGED MATERIAL TO POLYCARBONATE [ECO 240099]	04/24	
C	ADDED SHEET #2 ASSEMBLY & RIVETS [ECO 240126]	05/24	

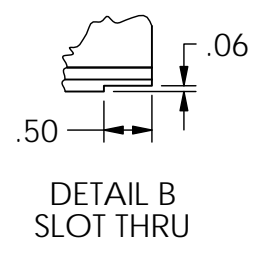
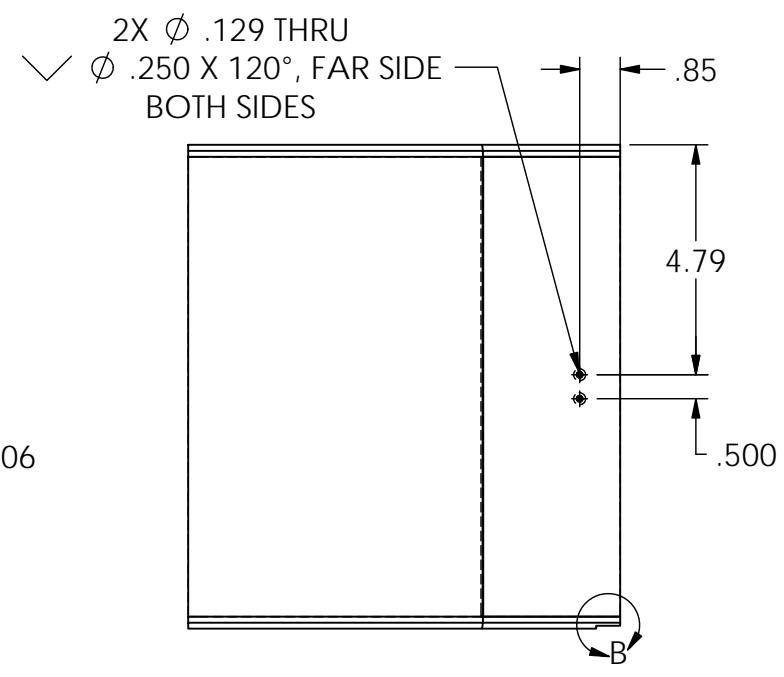
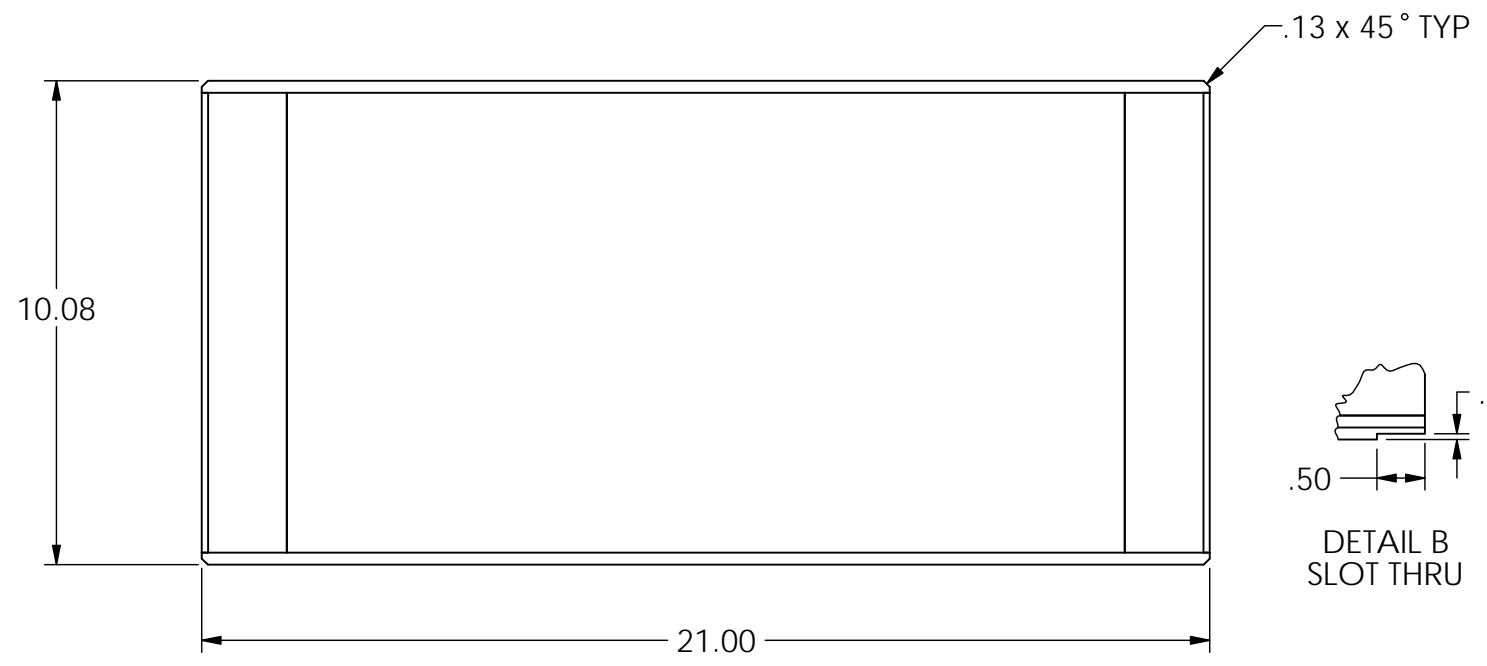
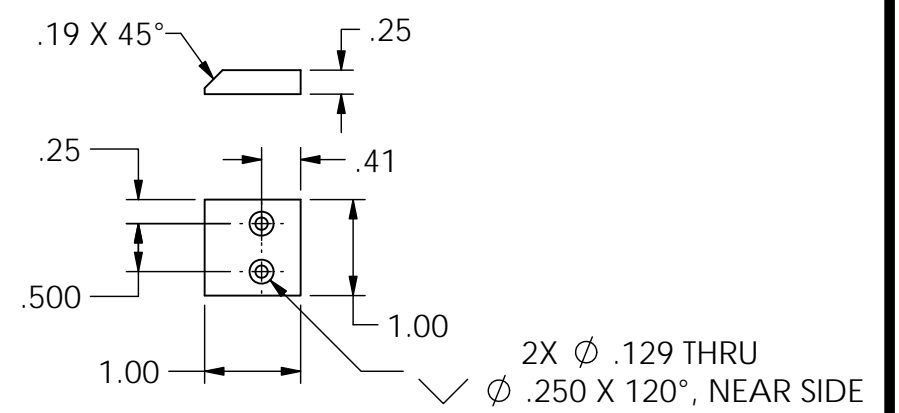
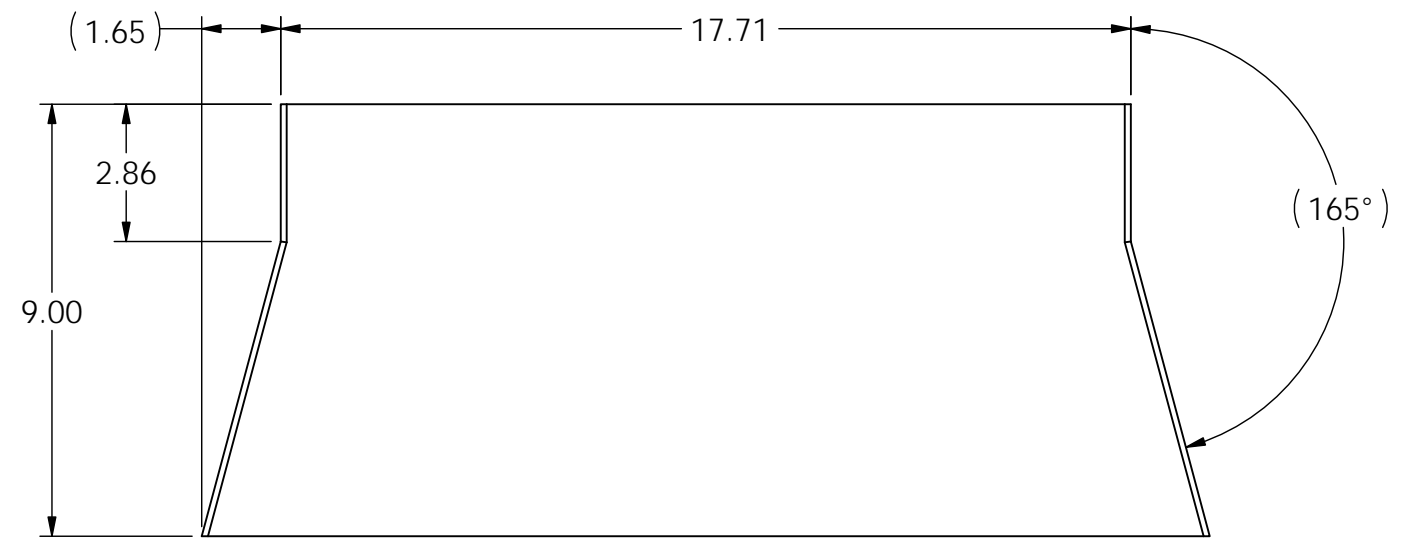

NOTE: THIS PRINT AND THE SUBJECT MATTER SHOWN HEREON ARE PROPRIETARY TO C.C. STEVEN & ASSOCIATES INC IT IS SUBMITTED IN CONFIDENCE FOR THE USE OF THE RECIPIENT ALONE. IT IS NOT TO BE REPRODUCED OR USED FOR ANY PURPOSE OTHER THAN MANUFACTURING ON A CCS/ CMI ORDER. OTHER USE ALLOWABLE ONLY WITH PRIOR WRITTEN CONSENT.

PART NO. PCS0075

NOTES: UNLESS OTHERWISE SPECIFIED:

DRILLED HOLES	
DIAMETER	TOLERANCE
.7656-1.000	+.007,-.003
.250-.750	+.005,-.002
.1875-.246	+.004,-.002
.00135-.185	+.003,-.002

DO NOT SCALE THE DRG.	DR	R. STUEVE	01/24	C.C. STEVEN & ASSOCIATES	
BREAK ALL SHARP EDGES	APP			www.CCSTEVEN.com	<i>C.C. Steven</i>
TOLERANCES:		MATERIAL	1/4" POLYCARBONATE	805-658-0207	
ALL DIMS. ARE IN INCHES COML. TOL. APPLY TO STOCK SIZES .XX = ±.01 .XXX = ±.005 ANGULAR MACH. SURFACES ✓		FINISH	NONE	TITLE HOOD, POLYCARBONATE, PCS CLEAN STATION XL	
DIMENSIONS APPLY AFTER FINISHING, HEAT TREATMENT AND PLATING		THIRD ANGLE PROJECTION		SIZE B	DATE 01/12/2024 MO / DAY / YR
				NEXT ASSY	DRAWING NO. PCS0075
				SCALE: 1:4	REV C
				SHEET 1 OF 2	

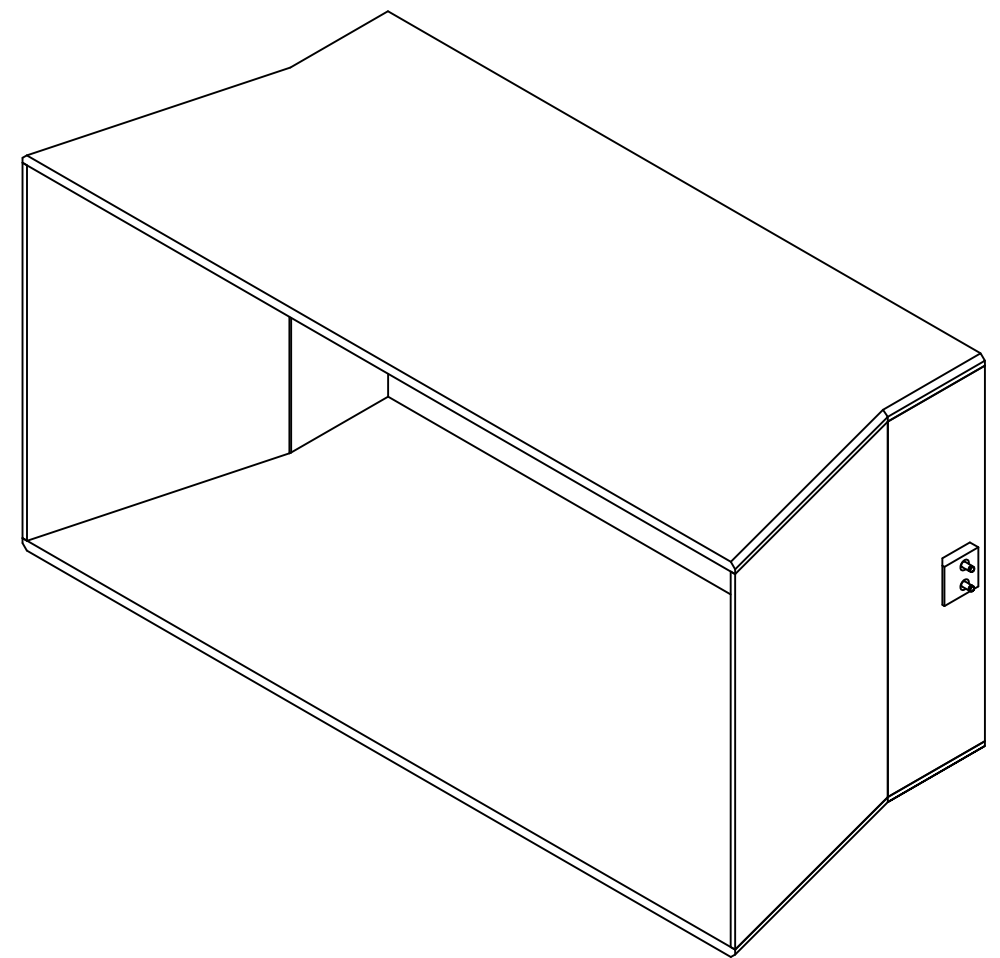
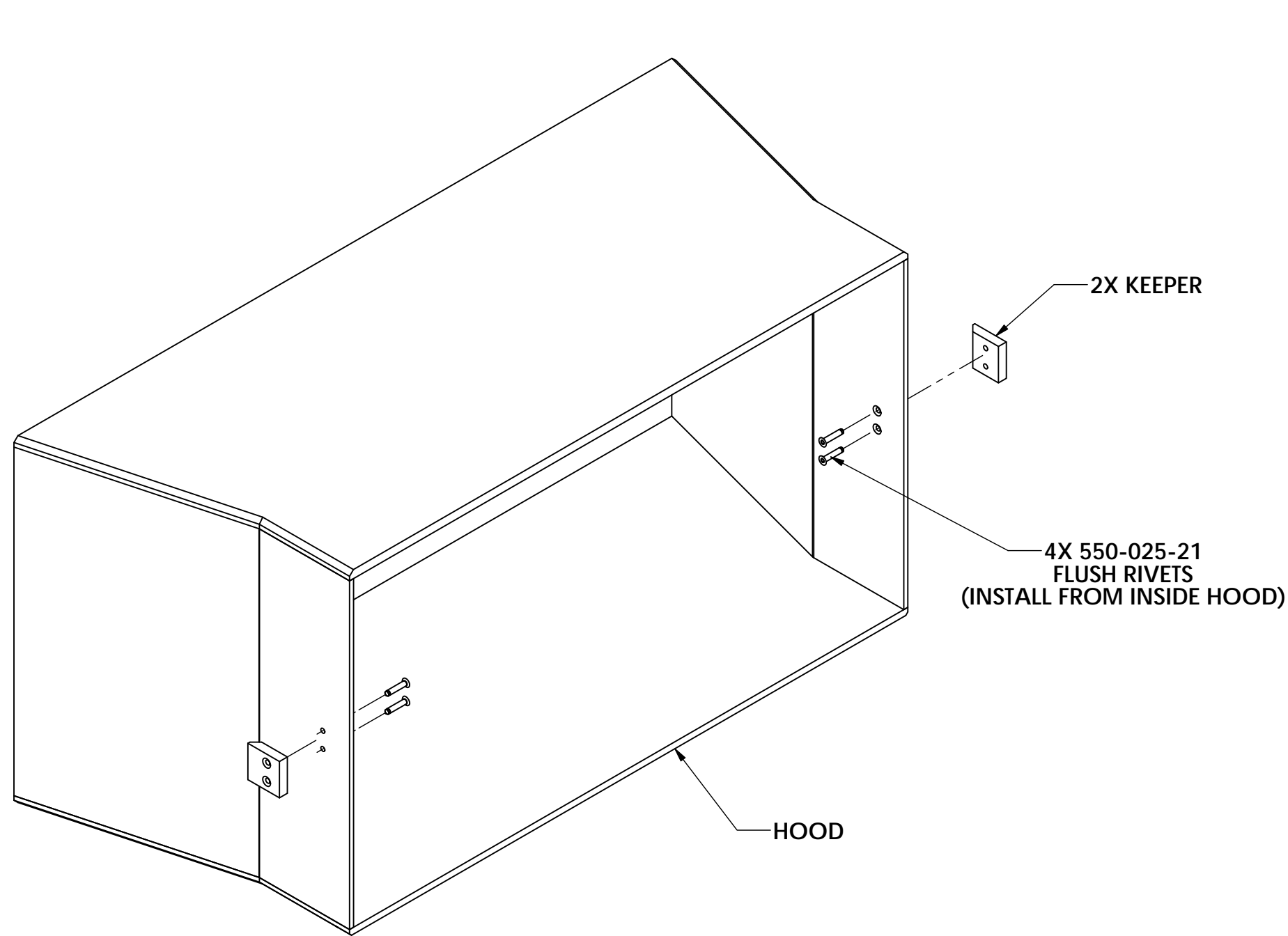

NOTE: THIS PRINT AND THE SUBJECT MATTER SHOWN HEREON ARE PROPRIETARY TO C.C. STEVEN & ASSOCIATES INC. IT IS SUBMITTED IN CONFIDENCE FOR THE USE OF THE RECIPIENT ALONE. IT IS NOT TO BE REPRODUCED OR USED FOR ANY PURPOSE OTHER THAN MANUFACTURING ON A CCS/ CMI ORDER. OTHER USE ALLOWABLE ONLY WITH PRIOR WRITTEN CONSENT.

PART NO. PCS0075

NOTES: UNLESS OTHERWISE SPECIFIED:

DRILLED HOLES	
DIAMETER	TOLERANCE
.7656-1.000	+.007,-.003
.250-.750	+.005,-.002
.1875-.246	+.004,-.002
.00135-.185	+.003,-.002

DO NOT SCALE THE DRG.	DR	R. STUEVE	01/24	C.C. STEVEN & ASSOCIATES www.CCSTEVEN.com 805-658-0207	
BREAK ALL SHARP EDGES	APP				
<b>TOLERANCES:</b> ALL DIMS. ARE IN INCHES COMPL. TOL. APPLY TO STOCK SIZES .XX = ±.01 .XXX = ±.005 ANGULAR MACH. SURFACES ✓ DIMENSIONS APPLY AFTER FINISHING, HEAT TREATMENT AND PLATING	MATERIAL	1/4" POLYCARBONATE		TITLE HOOD, POLYCARBONATE, PCS CLEAN STATION XL	
	FINISH	NONE			
THIRD ANGLE PROJECTION				SIZE B	DATE 01/12/2024 MO / DAY / YR
				DRAWING NO. PCS0075	REV C
NEXT ASSY				SCALE: 1:4	SHEET 2 OF 2